

OPERATOR'S MANUAL

HARLACHER H 41-2

AUTOMATIC COATING MACHINE

MAX. FRAME SIZE 2000 x 2100 MM

SERIAL NO. 41.8 17

(version from serial no. 41.800 up)

HARLACHER AG

Grossmattstrasse 25
CH-8964 Rudolfstetten
Switzerland

Tel. ++41 (0)571 33 83 66
Fax ++41 (0)571 33 63 12

REGISTER

Page

1. GENERAL INFORMATION ON THE H 41-2	3
1.1 Range of applications	
1.2 Machine data sheet	
2. SAFETY INSTRUCTIONS	4
2.1 Introduction	
2.2 Warnings and danger signs	
3. INSTALLATION AND COMMISSIONING TESTS	5
3.1 Location	
3.2 Transportation and unpacking	
3.3 Installation and dismounting	
3.4 Power supply	
3.5 Performance check	
4. SETTING-UP AND PREPARATION	7
5. FUNCTIONS AND CONTROLS	8
5.1 Upper frame holder	
5.2 Screen fixation	
5.3 Coating carriage	
5.4 Pneumatic functions	
5.5 Coating parameters	
6. INSTRUCTIONS FOR MAINTENANCE	10
6.1 Cleaning and lubrication	
6.2 Checks and adjustments	
7. DRAWINGS AND REGISTER	10
7.1 Register to drawings	
7.2 Structure	
7.3 Control panel	

1. GENERAL INFORMATION ON THE H 41-2

1.1 Range of application

This machine is intended for coating flat screen printing or textile printing stencils with photo-emulsion. It will coat coarse and fine mesh made of polyester, nylon or stainless steel attached with a screen tension of at least 10 N/cm to suitable printing frames of the specified sizes (see chapter 1.2, Machine data sheet).

Harlacher AG refuses any responsibility for possible damage and injury due to misuse of the coating machine!

1.2 Machine data sheet

Electric power (+6/-10%): 3x400V, 50/60Hz, 3,5Amp, 0,8kW
3x230V, 50/60Hz, 3,5Amp, 0,8kW

Check rating plate on machine for individual power requirements!

Compressed air: 5 to 10 bar, 5lt/min

Colors: gray RAL 7042 and blue RAL 5017

Noise emission: below 70 dB(A)

Dimensions and weights:

<input checked="" type="checkbox"/>	Screen size WxH, MM	Machine size LxWxH, MM	Recom. space LxWxH, MM	Crate size LxWxH, MM	Machine KG	Tara KG	Gross KG
...	1000x1300	2500x1000x2000	3800x3000x2300	2300x1450x1180	340	170	510
...	1250x1300	2750x1000x2000	4000x3000x2300	2300x1450x1180	350	170	520
...	1250x1700	2750x1000x2400	4000x3000x2700	2700x1450x1180	375	205	580
...	1500x1700	3000x1000x2400	4300x3000x2700	2700x1450x1180	385	205	590
...	1500x2100	3000x1000x2800	4300x3000x3100	3100x1450x1180	420	225	645
...	1750x2100	3250x1000x2800	4500x3000x3100	3100x1450x1180	430	225	655
...	1750x2500	3250x1000x3200	4500x3000x3500	3500x1450x1180	465	245	710
...	2000x2500	3500x1000x3200	4800x3000x3500	3500x1450x1180	475	245	720
...	2000x2900	3500x1000x3600	4800x3000x3900	3900x1450x1180	500	265	765
...	2250x2900	3750x1000x3600	5000x3000x3900	3900x1450x1180	510	265	775
...	2250x3300	3750x1000x4000	5000x3000x4300	4300x1450x1180	545	295	840
...	2500x3300	4000x1000x4000	5300x3000x4300	4300x1450x1180	555	295	850
...	2500x3700	4000x1000x4400	5300x3000x4700	4700x1450x1180	590	320	910
...

Instruction for calculating the coating trough profile lengths:

The standard profile lengths are to be calculated according to the undermentioned list. There are coating trough end pieces of different colors, i.e. red ones for the front and black ones for the back. A black coating trough is always 4/5" (20mm) shorter than a red one.

Frame width A (inside dimension)	4" - 20" 100-500mm	21 - 40" 501-1000mm	41 - 80" 1001-2000mm	above 81" above 2001mm
Trough length front (red)	A - 1 1/2" A - 40mm	A - 2" A - 50mm	A - 2 3/4" A - 70mm	A - 4" A - 100mm
Trough length back (black)	A - 2 1/3" A - 60mm	A - 2 3/4" A - 70mm	A - 3 1/2" A - 90mm	A - 4 3/4" A - 120mm

2. SAFETY INSTRUCTIONS

2.1 Introduction

All Hartacher equipment is designed for maximum safety of personnel, machine and material. It is in conformity with the provisions of the significant directives and standards.

This machine is determined for industrial use and must be operated by trained staff only. This Operator's Manual, especially its safety instructions and danger signs, must be obeyed at all times.

2.2 Warnings and danger signs



DIRECTIONS are information about technical requirements. Disobeying directions may lead to machine failures or loss of material.



CAUTION points to danger which may lead to damages of the machine and/or light to medium injuries.



WARNING points to danger which may lead to serious injuries and/or permanent physical damages.

3. INSTALLATION AND COMMISSIONING TESTS

3.1 Location

The location of the machine should be determined according to the following aspects:

- room without direct daylight or with covered windows,
- yellow light,
- hard, vibration-free floor,
- short distance for taking the coated screens to the oven,
- dust-free environment, constant room temperature and humidity.

The required space depends on the machine size:

- The space between the back of the machine and the wall must be of at least 30cm.
- On the left-hand-side (control panel) there must be at least 50cm, on the right-hand-side at least 30cm space.
- On height there must be at least 20cm space between machine and ceiling for the erection of the machine.
- In front of the machine there should be at least 150cm space for screen handling and machine operation. In case of very large screens, the required space has to be determined considering all local circumstances.

3.2 Transportation and unpacking



CAUTION: Suitable equipment must be used for lifting and transportation of the crate and heavy machine parts. See chapter 1.2, Machine data sheet, for crate size and weights.

Move the crate as close as possible to the planned location of the machine. Carefully open the top of the crate and check its contents. In case of shipping damages, immediately stop unpacking and contact the onforwarder or the shipping insurance company for further instructions.

Remove the front panel of the crate in order to have better access for unpacking heavy parts. Unwrap all parts and check the contents with the packing list of the shipping documents. Report missing parts at once to Harlacher AG.

3.3 Installation and dismantling



CAUTION: Suitable equipment must be used for handling of heavy machine parts. Secure columns (1/2) after erection to prevent them from tipping over until the connecting tubes (3/4) are mounted.

If the machine is delivered in sub-assemblies, final assembly should be mounted in the following sequence:

1. Set up control column (1) carefully and align it.
2. Attach base plate (3) and drive shafts (5) to the control column (1). Shim base plate to keep it horizontal. Fix connecting tubes (4) over drive shafts. Observe numbering on flanges of connecting tubes and columns for correct location. Use special screws with blue retension section for drive shafts. Do not yet tighten these screws.
3. Set up and align side column (2). Join side console and drive shafts (5) slowly. Fix other end of connecting tubes (4) to side column. Tighten all screws, also the special screws of the drive shaft.
4. Set in and fix lower frame holding beam (6).
5. Remove shipping protection on both columns from coating carriage bearing plate (14).
6. Position coating carriage (7) between bearing plates (14) and screw tight. Ensure that cable conduit (15) comes to rest on control console side. Only M6x10mm screws must be used for coating carriage on bearing plates!
7. Level machine with its levelling feet. Set water level on to coating trough carrier (17) and bearing plate (14).
8. Set upper frame holding beam (8) from the back on to guide rail (18) inbetween control column and side column, dismantle front bearing plate (19) before. Re-fit bearing plates (19) and adjust for 0.1-0.3mm play. Attach magnet rod (26) for 2-3mm distance to magnetic switches.
Adjust lower frame holder (28) by moving holding beam (6) in such way, that a screen will be parallel to guide rails (18).
9. Insert all tubes and cables from cable conduit (15) of coating carriage (7) into cable duct (13). Connect all tubes and cables inside control column (1) according to their numbers marked on the flanges.
11. Set endpiece of cable conduit (15) into cable duct (13) and fix with cover flange.
12. Machines for screen height 300cm or more must be secured from upper connecting tubes (4) to wall by supplied fixations.

Dismounting of the machine is to be done in reverse order. Make sure to have the power supply disconnected before starting!

3.4 Power supply

3.4.1 Current supply



WARNING: The current supply must be connected to the machine by a licenced electrician according to the diagram supplied with the machine.

Install the current supply (30) of sufficient power according to the diagram and the rating plate on the machine.

3.4.2 Compressed air supply

CAUTION: Shut off the air supply pipeline and release the pressure in the system before starting, unless the pipeline is equipped with automatically locking quick fittings.



Be aware that the electric main switch of the coating machine does not shut off the air pressure! Therefore, always disconnect the air supply (31) before working on the pneumatic system of the machine.

Install the compressed air supply (31) with 5 bar minimum pressure. A water collector (33) and a pressure control switch are installed in the control column (1).

3.5 Performance check

CAUTION: All micro switches of the machine have been adjusted prior to shipment. However, for safety reasons the correct function of these switches must be checked as follows before preparation for coating.



Check the switch functions for the following positions carefully by short movements of the carriages, keep one hand on the emergency stop switch:

- Coating carriage (7), lower switching point (area 50, on micro switch) and upper switching point (area 51, on magnet rod 26).
- Upper frame holding beam (8), upper switching point (area 52, on micro switch), lower switching point (area 51, on magnet rod 26). During normal operation the lower position will be given by frame contact (mechanical stop by friction clutch).

If necessary, adjust these switches for proper function.

The remaining magnetic switches can be checked in the coating mode. Check the distance between magnets and switches first, it must be of 2-3mm. Then, run a test without coating troughs (34) and no screen in the machine.

Check all pneumatic movements at the same time. Chapter 6, INSTRUCTIONS FOR MAINTENANCE, contains more information on the adjustment of the pneumatic movements.

4. SETTING-UP AND PREPARATION

CAUTION: Correct adaptation of the machine to the actual screen size is essential for good coating results and in order to avoid damage on material and machine.



Make sure to use suitable equipment to handle large or heavy screens.

Before coating a screen, the machine has to be adapted to the respective screen size as follows:

- Upper and lower frame holders (27 and 28) have to be pre-set for the approximate screen height.

- Measuring of the screen frame profile and adjustment of the coating distance on the upper and lower side. The adjusting devices (54 and 55) are located on the control column side.

CAUTION:



When choosing the distance too small, the front coating trough (34) collides with the screen frame and might get damaged. Always set the screens with their mesh side (print side) towards the back into the machine!
Make sure to hold the frame only on the side when lowering the upper frame holder. Do not get the hands caught between frame and frame holder!

- Select a suitable pair of coating troughs (34) and fix them. The red coating trough has always to be installed in the front and the black coating trough in the back. See chapter 1.2, Machine data sheet, for correct coating trough lengths. Always remove the the black edge protection profile before coating and apply it to the coating troughs when they are not used.
- Fill the coating troughs with a sufficient amount of emulsion. The maximum content of the coating troughs is 1 liter for 1 meter length. For best coating results, refer to the product data sheet of the emulsion supplier.

5. FUNCTIONS AND CONTROLS

CAUTION:



All carriage movements are protected by safety clutches in case of a collision. However, it is essential to check for free travel, before starting any movement and to keep out of the dangerous area (marked with yellow and black stripes) at all times.

5.1 Upper frame holder and screen fixation

DIRECTION:

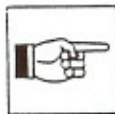

Always set screens with their mesh side (print side) towards the back into the machine. Whenever possible, coat screens in portrait position rather than landscape position.

By pressing the the respective foot switch the frame holder (29) moves upward or downward. Insert the screen and hold it on its side in vertical position. Move the frame holder carefully downward to fix the screen. Center it according to the marks on the frame holders.

5.2 Coating carriage

The coating carriage may be moved up and down individually by setting zero passes for print side and squeegee side and pressing START/STOP.

Always bring the carriage to its basic position by pressing STOP before starting the automatic coating action.

5.3 Pneumatic functions

There are three pneumatic functions:

trough in / trough out squeegee side
trough in / trough out printing side
troughs tilt up / set down

5.4 Coating parameters

- COATING PS: (number of coatings on the printing side)
- COATING SS: (number of coatings on the squeegee side)
- COATING SPEED: (speed of coating carriage during coating process)
- DELAY TIME START/STOP: (delay time before start of coating action until emulsion reaches mesh)

- PRESSURE PS: (coating trough pressure against mesh on printing side)
- PRESSURE SS: (coating trough pressure against mesh on squeegee side)

All parameters can be preset on the control panel.

Before the coating action is started make sure that the following conditions are fulfilled:

- screen in position, centered and securely locked
- coating carriage in the lowest position - on the limit switch
- correct set of coating troughs installed and filled
- carriage travel set for actual frame profile thickness

If not all conditions are fulfilled, do not start coating.

5.5 Coating cycle

After the key START has been pressed, the coating cycle runs as follows:

1. Coating carriage moves up to the lower end of the coating area
2. One or both coating troughs move towards the mesh
3. One or both coating troughs tilt upwards
4. "DELAY TIME START/STOP" runs (so that the emulsion reaches the mesh)
5. Coating action at pre-set speed
6. Coating troughs tilt back at upper end
7. "DELAY TIME START/STOP" for emulsion return runs
8. Stripping of emulsion residues by short upward movement
9. Coating troughs move away from the mesh
10. Coating carriage moves down at maximum speed to the lower end of the screen
11. In case several coating passes have been selected, step 2 starts again
12. After completing the required number of coatings, the coating carriage returns to its starting position

At this point the screen is removed for drying and coating of a new screen can start. If required, use the emergency switch to stop the coating action. Interruptions are possible by pressing STOP (1x = pause, continue with START, 2x = program stop, coating troughs out, 3x = reset coating trough to basic position, ready for restart).

6. INSTRUCTIONS FOR MAINTENANCE

DIRECTION: Follow these instructions carefully for a long and failure-free lifespan of the coating machine. Disobedience will result in the loss of warranty coverage.

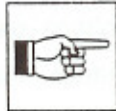

6.1 Cleaning and lubrication

- Daily:**
- Clean coating troughs thoroughly and put on edge protection profiles.
 - If equipped with edge cleaning system, clean sponge and water container, resp. cleaning squeegee.
- Weekly:**
- Remove emulsion residues and stains from coating carriage, cylinders and guide rails.
 - Empty water collector (33) in control column (1).
- Monthly:**
- Clean carriage guide rails and lubricate lightly with machine grease.
 - After cleaning, lubricate piston rods of pneumatic cylinders lightly with oil.

6.2 Checks and adjustments

- Weekly:**
- Visual check for obvious damages, loose drive belts or off-set carriages e.g. as a consequence of a collision.
- Monthly:**
- Check torsion of friction clutches in both carriage drives, readjust if necessary. For safety reasons, the torsion should be set as low as possible.

CAUTION: Damages must be checked out and repaired immediately. In case of doubt about the consequences of a damage, report to the after sales service of Harlacher AG or to the official Harlacher representative.



7. DRAWINGS AND REGISTERS

7.1 Register to drawings

- 1 Control column
- 2 Side column
- 3 Base plate
- 4 Connecting tubes
- 5 Drive shafts (hexagonal tube), coating carriage and upper frame holder
- 6 Lower frame holding beam
- 7 Coating carriage
- 8 Upper frame holding beam
- 9 Control panel
- 10 Supporting beam

- 13 Cable duct, coating carriage
- 14 Bearing plate, coating carriage
- 15 Cable conduit, coating carriage

- 17 Coating trough carrier
- 18 Guide rail
- 19 Bearing plate
- 20 End piece
- 21 Clamping for coating troughs

- 26 Magnet rod
- 27 Upper frame holder
- 28 Lower frame holder
- 29 Foot switch for upper frame holder
- 30 Current supply
- 31 Compressed air supply

- 33 Water collector, air supply
- 34 Coating troughs

- 50 Switching point, coating carriage low
- 51 Switching point, coating carriage high
- 52 Switching point, frame holder high

- 54 Lower frame profile width adjustment
- 55 Upper frame profile width adjustment

- 75 Emergency stop switch
- 76 Main switch

HARLACHER AG

Grossmattstrasse 25
CH-8964 Rudolfstetten
Switzerland

Tel. ++41 (0)57/ 33 83 66
Fax ++41 (0)57/ 33 63 12

BE41_2.DOC, June 1995

 **H41-2**

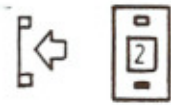
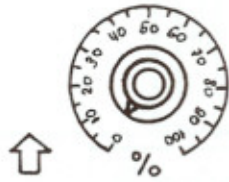
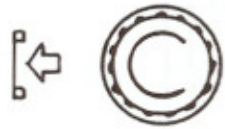

START



STOP



COATING PRESSURE
PRINT SIDE (PS)

COATING PRESSURE
SQUEEGEE SIDE (SS)

COATING SPEED

NO. OF PASSES PS

NO. OF PASSES SS

DWELL TIME (SEC.)

PROGRAM START / STOP

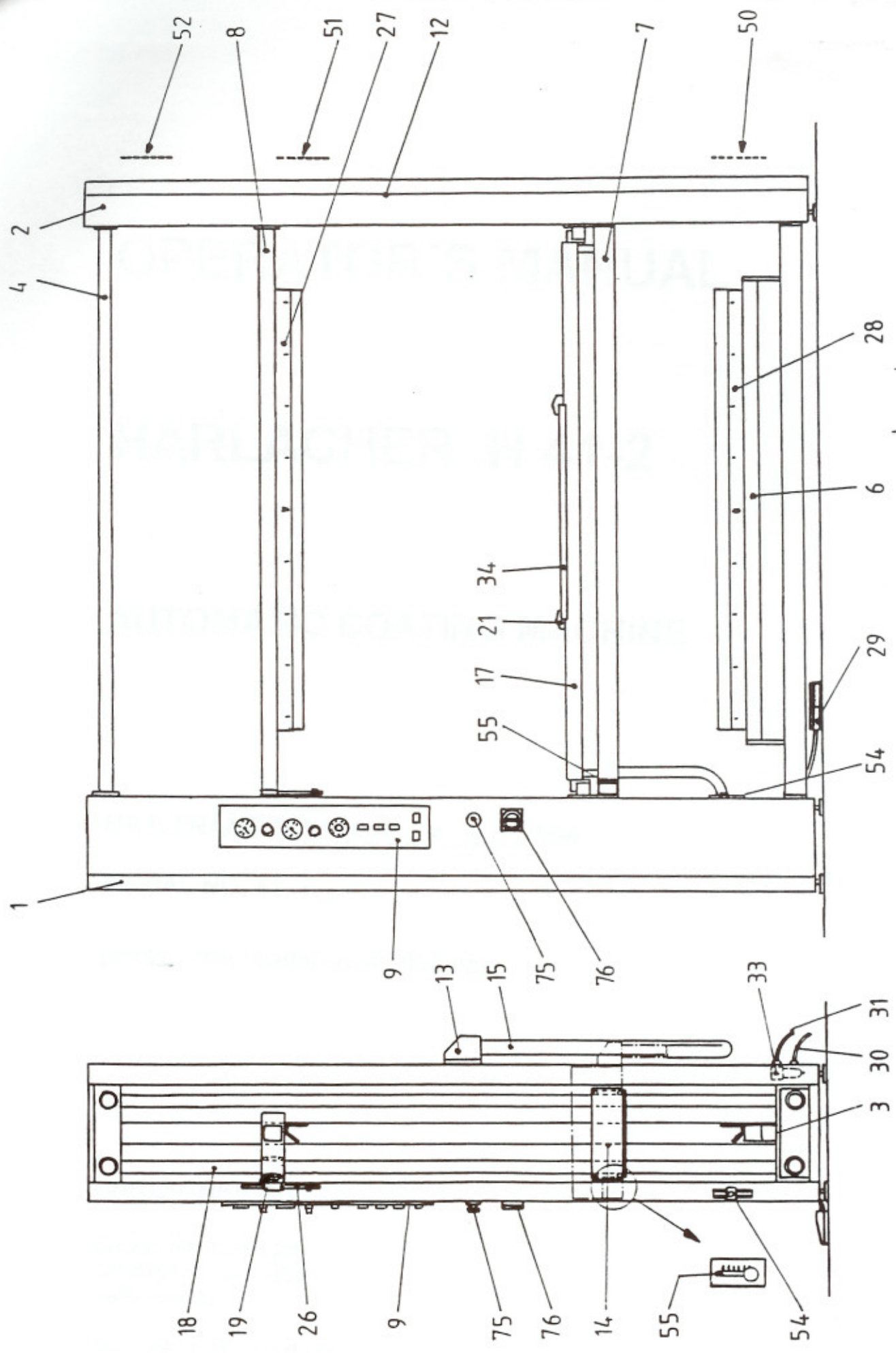

13